

# Whirlpool Electric Slide-In Range Installation Instructions

## PRODUCT MODEL NUMBERS

WEE750H0H

WEEA25H0H

## Installation Requirements

### PRODUCT DIMENSIONS

These instructions cover several models. Your model may appear different from the models depicted. Dimensions given are maximum dimensions across all models.

#### Model WEE750H0H

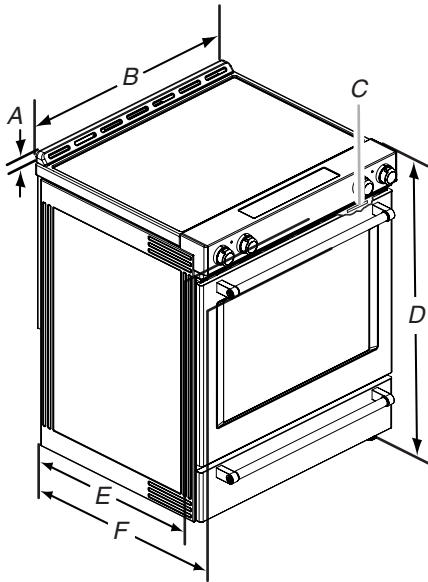

- A.  $1\frac{3}{16}$ " (3.0 cm) height from cooktop to top of vent
- B.  $29\frac{7}{8}$ " (75.9 cm)
- C. Model/serial/rating plate (located behind the oven door on the top right-hand side of the oven frame)
- D. 36" (91.4 cm) height to top of cooktop edge with leveling legs screwed in all the way\*
- E. 27" (68.8 cm)
- F.  $28\frac{5}{8}$ " (72.7 cm) max. depth from handle to back of range

**IMPORTANT:** Range must be level after installation. Follow the instructions in the "Level Range" section. Using the cooktop as a reference for leveling the range is not recommended.

\* Range can be raised approximately 1" (2.5 cm) by adjusting the leveling legs.

### CABINET DIMENSIONS

Cabinet opening dimensions shown are for 25" (64.0 cm) countertop depth, 24" (61.0 cm) base cabinet depth and 36" (91.4 cm) countertop height.

**IMPORTANT:** If installing a range hood or microwave hood combination above the range, follow the range hood or microwave hood combination installation instructions for dimensional clearances above the cooktop surface.

Range may be installed next to combustible walls with zero clearance.

**NOTE:** When installed in a slide-in cutout, the front of oven door may protrude beyond the base cabinet.

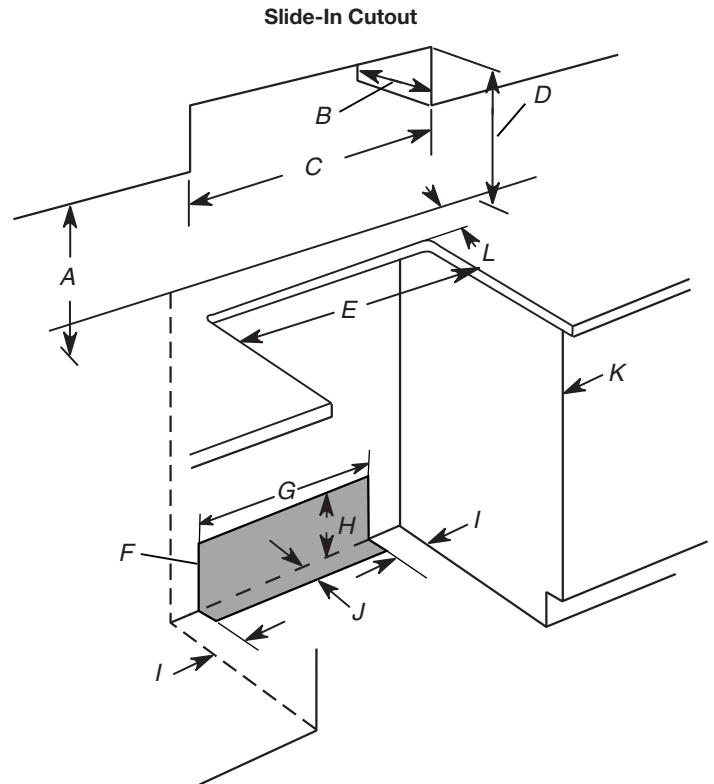

- A. 18" (45.7 cm) upper side cabinet to countertop
- B. 13" (33 cm) max. upper cabinet depth
- C. 30" (76.2 cm) min. opening width
- D. For minimum clearance to top of cooktop, see NOTE\*.
- E. 30" (76.2 cm) min. opening width
- F. The shaded area is recommended for installation of grounded outlet.
- G.  $13\frac{1}{8}$ " (33.3 cm)
- H.  $7\frac{11}{16}$ " (19.5 cm)
- I.  $4\frac{13}{16}$ " (12.2 cm)
- J.  $3\frac{11}{16}$ " (9.4 cm) plus measurement of L
- K. Cabinet door or hinges should not extend into the cutout.
- L. Remaining counter depth should not exceed  $2\frac{1}{4}$ " (5.7 cm).

\* **NOTE:** 24" (61.0 cm) minimum when bottom of wood or metal cabinet is shielded by not less than 1/4" (6.4 mm) flame retardant millboard covered with not less than No. 28 MSG sheet steel, 0.015" (0.4 mm) stainless steel, 0.024" (0.6 mm) aluminum or 0.020" (0.5 mm) copper.  
30" (76.2 cm) minimum clearance between the top of the cooking platform and the bottom of an uncovered wood or metal cabinet.

## ⚠ WARNING



### Electrical Shock Hazard

Electrically ground range.

Failure to do so can result in death, fire, or electrical shock.

### Electrical Connection

To properly install your range, you must determine the type of electrical connection you will be using and follow the instructions provided for it here.

- Range must be connected to the proper electrical voltage and frequency as specified on the model/serial/rating plate. The model/serial/rating plate is located behind the oven door on the top right-hand side of the oven frame.
- This range is manufactured with the neutral terminal connected to the cabinet. Use a 3-wire, UL Listed, 40- or 50-amp power supply cord (pigtail). See the following Range Rating chart. If local codes do not permit ground through the neutral, use a 4-wire power supply cord rated at 250 volts, 40- or 50-amps and investigated for use with ranges.

Range Rating*	Specified Rating of Power Supply Cord Kit and Circuit Protection	
	120/240 Volts	120/208 Volts
8.8 - 16.5 KW	7.8 - 12.5 KW	40 or 50**
16.6 - 22.5 KW	12.6 - 18.5 KW	50

\* The NEC calculated load is less than the total connected load listed on the model/serial/rating plate.

\*\* If connecting to a 50-amp circuit, use a 50-amp rated cord with kit. For 50-amp rated cord kits, use kits that specify use with a nominal 1<sup>3</sup>/<sub>8</sub>" (3.5 cm) diameter connection opening.

- A circuit breaker is recommended.